

7.5 in (190.5 mm)

10 in (254 mm)

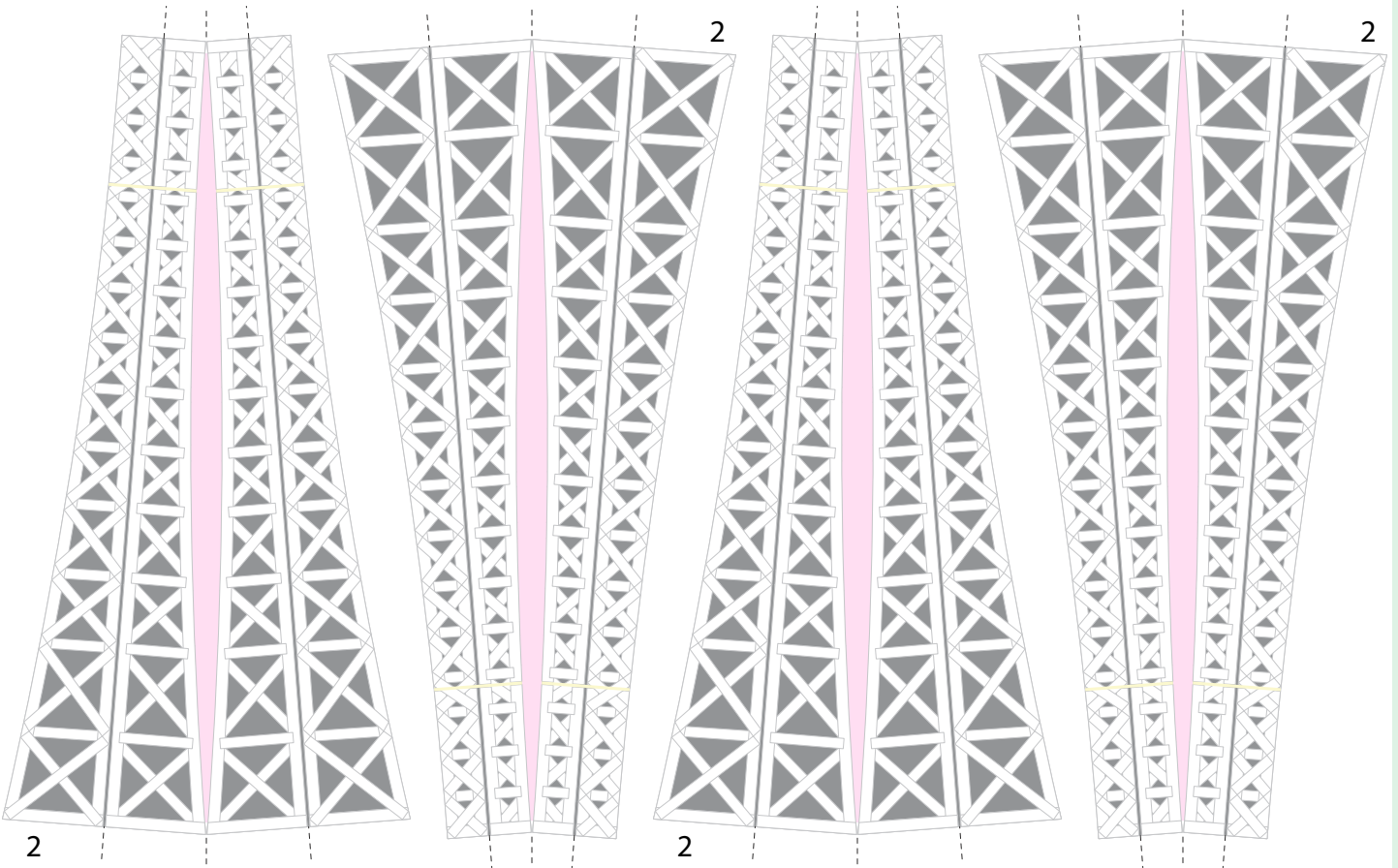
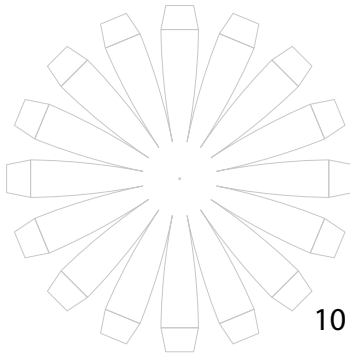
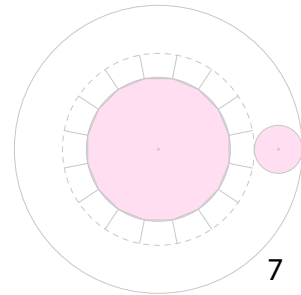
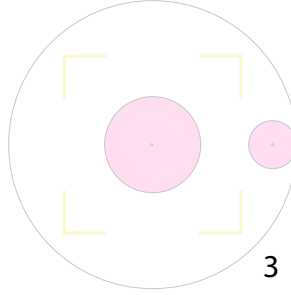
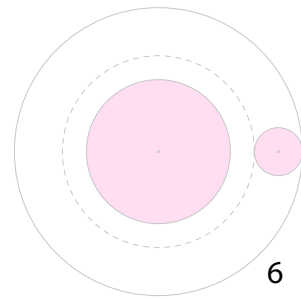
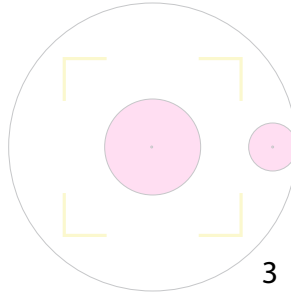
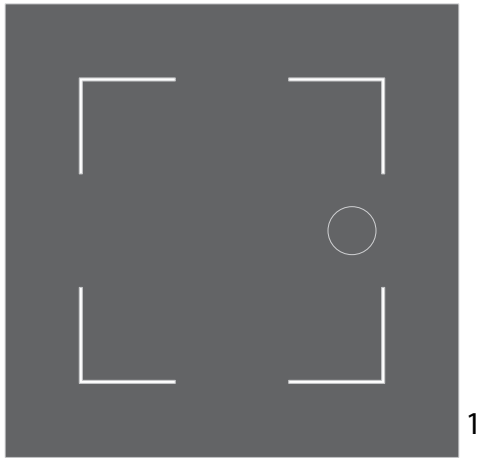

7.5 in (190.5 mm)

10 in (254 mm)

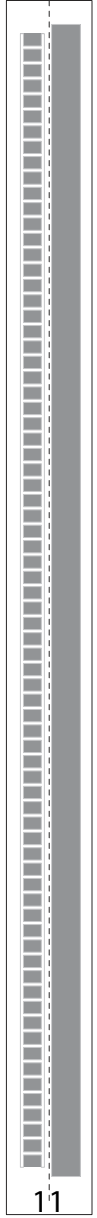
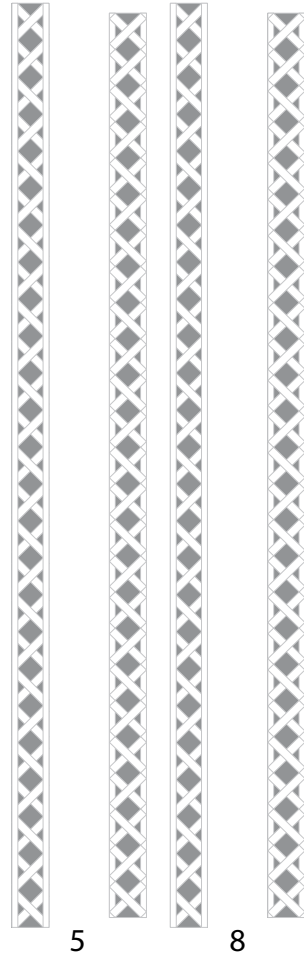
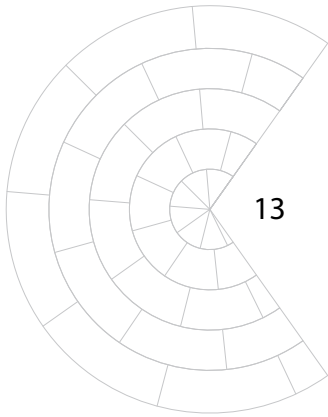

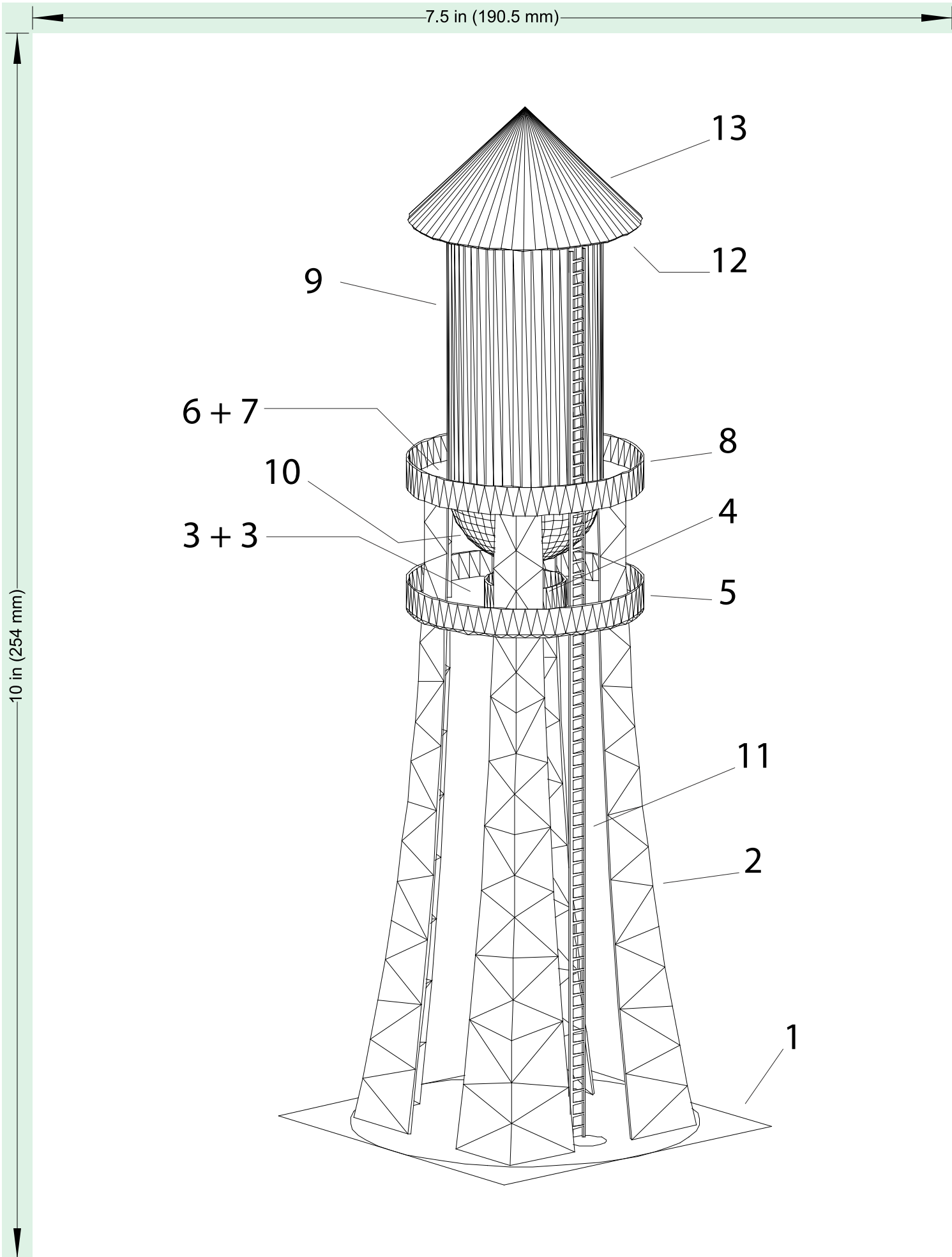

This is a water tower in approximately 1:160 scale, designed for the Spayneville project (<http://spayneville.blogspot.com/>). The Spayneville water tower was built in 1958 of welded steel, following the mysterious disappearance of the original, wooden water tower which had stood in the same location since the town was founded in 1893. The new tower quickly became a favorite hangout for the young men of the area.

To assemble:

Cut out part 1 and glue it to a flat, solid base.

Score each part 2 using the dashed lines as guides. Cut out each part 2. Fold the two outer portions away from the printed side and glue them flat against the backs of the inner portions. Fold each part 2 away from the printed side 90 degrees, then flatten again. Carefully remove the pink portion of each part 2 leaving the top and bottom ends of the parts connected. Glue the broad ends of each part 2 to one of the L-shaped locations on part 1. Apply a little glue along the curved edges where you removed the pink portions, and gently hold the edges together until the glue sets.

Cut out the pink portions of parts 3. Cut out parts 3 and glue them back to back, aligning the edges and holes. Remove the yellow portions of parts 3.

Cut out parts 4. Note the slight difference in their lengths; the shorter part 4 is the inside of a ring. Overlap the two parts 4 back to back by about half their length and glue them together. Roll the parts into a cylinder with the shorter part 4 on the inside and glue the ring shut. Apply glue to one edge of the ring and attach it to one side of parts 3 over the center hole.

Cut out parts 5. Note the slight difference in their lengths. Wrap one edge of the shorter part 5 around the edge of parts 3 with the printed side on the inside and glue in place. Wrap the longer part 5 around the shorter part 5 with the printed side on the outside, and overlapping by about half the length of the part. Glue the unprinted sides of the parts together.

Carefully guide the top ends of parts 2 through the L-shaped cutouts in parts 3, aligning the small hole with the grey circle on part 1. Glue parts 3 to parts 2 at the yellow locations on parts 2.

Cut out the pink portions of parts 6 and 7. Cut out parts 6 and 7 and glue them back to back, aligning the edges and holes.

Cut out parts 8. Note the slight difference in their lengths. Wrap one edge of the shorter part 8 around the edge of parts 6 and 7 with the printed side on the inside and part 7 on the bottom and glue in place. Wrap the longer part 8 around the shorter part 8 with the printed side on the outside, and overlapping by about half the length of the part. Glue the unprinted sides of the parts together.

Cut out part 9 and its connector strip. Glue the connector strip to the back of one end of part 9, overlapping it about halfway. Roll part 9 into a cylinder and glue shut at the connector. Apply glue to the bottom edge of part 9 and attach it to part 6 on the dashed circle with the dark grey area aligned over the hole in part 6.

Score the tabs of part 10 and cut it out. Curl the petals of part 10 away from the printed side, and fold the tabs away from the printed side. Glue the tabs of part 10 to the indicated locations on part 7, just covering the dashed lines.

Apply glue to the tops of parts 2 and set assembly 6-7-8-9-10 onto them, aligning the small hole in parts 6 and 7 with the matching hole in parts 3 and the grey circle on part 1; part 7 should sit square atop parts 2.

Score part 11 along the dashed line. Cut out part 11 at the boundary box, fold it double away from the printed side and glue the back together. Apply weight until the glue sets, then cut out the ladder around its grey background. Insert the ladder through the holes in parts 6, 7, and 3. Glue the bottom end of the ladder to part 1 at the back of the grey circle. Glue the back of the ladder to the edge of parts 3. Glue the back of the ladder to the edge of parts 6 and 7. Finally, glue the top end of the ladder to the surface of part 9.